

---

# Reliability of Precision Optical Performance AlInGaP LED Lamps in Traffic Signals and Variable Message Signs

## Application Brief I-004

---

### Introduction

The most recent advancement in light emitting diode (LED) technology is the new aluminum indium gallium phosphide (AlInGaP) Precision Optical Performance lamps designed specifically for use in traffic management applications. These Precision Optical Performance LED lamps offer light output performance superior to that of other technologies with predictable, superior, and stable long term performance.

The reliability of Precision Optical Performance AlInGaP LED technology is not well understood by many transportation authorities, and therefore, they leave it to the contract engineering firms to correctly design LED devices into the traffic signals and variable message signs (VMS) to achieve the desired long term reliability in the units that are installed within their jurisdictions. In many cases, the contract engineering firms and the signal/sign designers are not familiar with LED technology to a level that would permit them to accomplish effective, reliable designs.

This application note discusses the reliability of Precision Optical

Performance AlInGaP LED technology in traffic signals and VMS from respective view points of the transportation engineer, the contracting engineer, and the signal/sign designer.

### The Anatomy of a Precision Optical Performance AlInGaP LED, T-1 $\frac{3}{4}$ Plastic Lamp

The anatomy of a plastic, Precision Optical Performance AlInGaP LED, T-1 $\frac{3}{4}$  plastic lamp is pictured in Figure 1. The lamp is composed of a lead frame, the LED chip, and an encapsulating

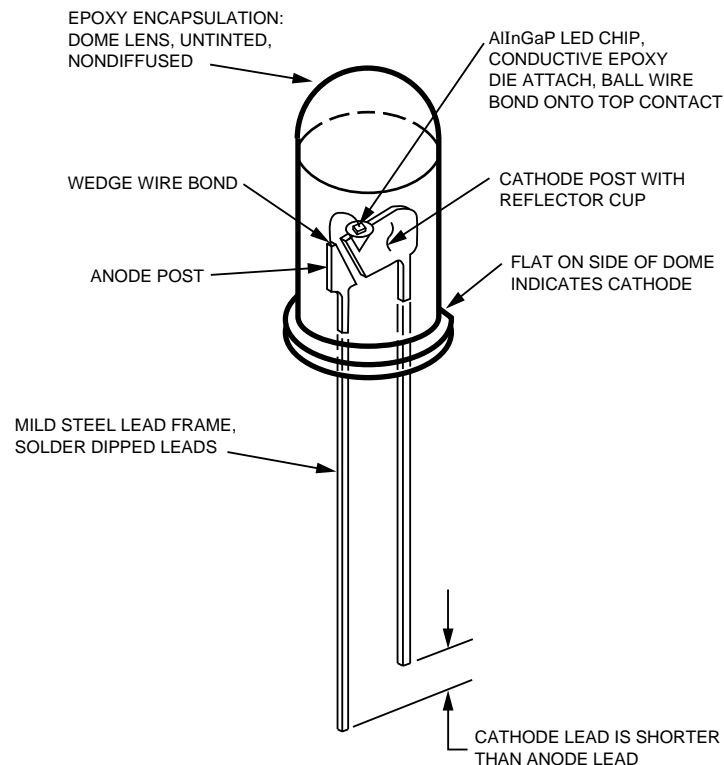

**Figure 1. The Anatomy of a Precision Optical Performance AlInGaP LED T-1 $\frac{3}{4}$  Plastic Lamp.**

epoxy that forms the device package. The AlInGaP LED chip is die attached to the cathode lead with an electrically conductive epoxy. The top contact on the LED chip is wire bonded to the anode lead with fine gold wire. An optical grade encapsulating epoxy is cast around the lead frame and LED chip to form the lamp dome. The encapsulating epoxy is cured at an elevated temperature to ensure 100% cross-linking of the epoxy molecules. The lead frame is made of mild steel and is solder dipped for solderability. The LED chip sits in a reflector cup on top of the cathode lead which reflects forward the side emitted light from the LED chip. Each Hewlett-Packard LED lamp is 100% electrically/optically tested for electrical parameters, light output, and color.

Reliability of an LED lamp is dependent upon the integrity of the encapsulating epoxy package and wire bond. If the integrity of the epoxy lamp package is maintained and the amount of current passed through the LED and wire bond does not exceed maximum limits the reliability of the lamp is assured.

### **AllInGaP LED Chips Provide Superior Reliability**

The details of an AllInGaP LED chip are shown in Figure 2. Of significance is the basic structure of the LED chip. Two important characteristics of the AllInGaP five layer epitaxy light emitting structure are 1) superior light output performance for a given drive current, compared to other technologies, and 2) stable and predictable long term low light output degradation that is not temperature dependent. The GaP

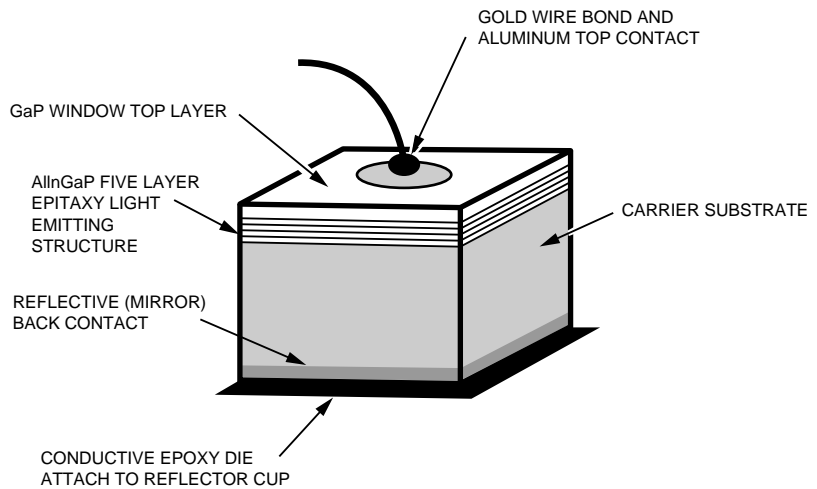

**Figure 2. Details of an AllInGaP LED Chip.**

window top layer, that provides enhanced light output from the LED chip, also provides superior resistance to light output degradation due to any possible moisture absorption within the encapsulating epoxy. The aluminum atoms contained within the five layer light emitting epitaxy are “locked” into the crystal structure, thus are protected from reaction with oxygen contained in any absorbed moisture. The conductive die attach epoxy forms a strong, reliable, electrical and mechanical bond between the conductive back contact and the base of the reflector cup on the cathode lead.

### **Long Term Reliability of Precision Optical Performance AllInGaP LED Lamps, an Important Consideration**

The long term reliability of Precision Optical Performance AllInGaP LED lamps, compared to existing technologies, such as incandescent lamps, is an important consideration for those who specify LED traffic signals and LED variable message signs (VMS). Transportation engineers expect LED traffic signals and LED VMS to operate for 100,000

elapsed time calendar hours, or 11.4 years, without the need for LED lamp replacement due to either catastrophic failure or excessive light output degradation.

Traffic signals and VMS signs require routine maintenance. This is particularly evident with the cost of required replacement of the incandescent lamps in traffic signals due to filament burn out. Incandescent lamp replacement is usually made on a routine basis, or on an emergency basis, especially if it is the red traffic signal that is out. This is one reason why many traffic management authorities are using LED traffic signals and LED VMS. Since Precision Optical Performance AllInGaP LED lamps are semiconductor devices, they do not suffer from filament burn out, and therefore, do not require routine lamp replacement and very rarely would ever need emergency replacement due to catastrophic failure. Thus, the cost of operational maintenance to a transportation authority is significantly reduced with the use of LED traffic signals and LED VMS signs.

Of particular concern are the effects of the following on long term operation:

- LED light output degradation characteristics of Precision Optical Performance AllInGaP LED lamps.
- Mean time between (possible) failures for Precision Optical Performance AllInGaP LED devices, MTBF.
- What happens when a Precision Optical Performance AllInGaP LED lamp is over heated.
- The effect of extreme temperatures on Precision Optical Performance AllInGaP LED lamps.
- The effect of exposure to long term high humidity and condensing moisture.
- The effect of exposure to direct sunlight (ultraviolet light).

### Packaging and LED Drive Current Influence the Reliability of Precision Optical Performance AllInGaP LED Lamps

The reliability of Precision Optical Performance AllInGaP lamps in LED traffic signals or LED VMS depends upon the way the LED lamps are packaged in the assembly. If care is taken to package the LED lamps correctly, following established semiconductor circuit assembly practices, protecting the LED devices from condensing moisture and over heating, LED signals and VMS should exhibit mean time between possible catastrophic failures, MTBF, far in excess of 100,000 hours.

### Light Output Degradation of Precision Optical Performance AllInGaP LED Lamps Compared to Incandescent Lamps

As with all light sources, the light output from an LED lamp degrades over time. The time needed to reach a given amount of light

output degradation for a Precision Optical Performance AllInGaP LED lamp is considerably longer than for an incandescent lamp. This means that for any given length of time, the amount of light output degradation for a Precision Optical Performance AllInGaP LED lamp is much less than that of an incandescent lamp.

Light output degradation of an incandescent lamp is due to tungsten atoms “boiling off” from the hot wire filament being deposited onto the inside of the glass envelope. Light output reduction to 50% due to this tungsten deposition can occur as early as 1500 hours for a high wattage incandescent lamp. Burn out of an incandescent lamp occurs when a notch forms in the hot tungsten wire filament, due to tungsten atom “boil-off”, causing the wire filament to break.

Precision Optical Performance AllInGaP LED lamps, being semiconductor devices, have neither of these characteristics.

### Light Output Degradation for Precision Optical Performance AllInGaP LED Technology

Light output degradation for AllInGaP LED technology is a first

order function of drive current, is a logarithmic function of on-time, and is essentially not temperature dependent. High temperature operating life tests, HTOL, and low temperature operating life tests, LTOL, are performed to gather long term light output degradation and reliability data. The statistical average long term light output degradation for Precision Optical Performance AllInGaP LED lamps, operated at 20 mA dc in an ambient temperature of 55°C (131°F), is presented in Figure 3. The graph shows a statistical average light output degradation of -10% at 10,000 hours of on-time, projected out to -25% degradation at 50,000 hours of on-time. Hewlett-Packard has on-going HTOL testing in progress to obtain additional long term degradation information.

### Recommended Drive Currents for AllInGaP LED Lamps:

Based on the above projected light output degradation characteristics, it is recommended that designers use LED drive currents between 10 mA and 30 mA for best overall long term performance. Drive currents in excess of 30 mA do produce higher light output, but with a considerable penalty in high long term light output degradation, and therefore

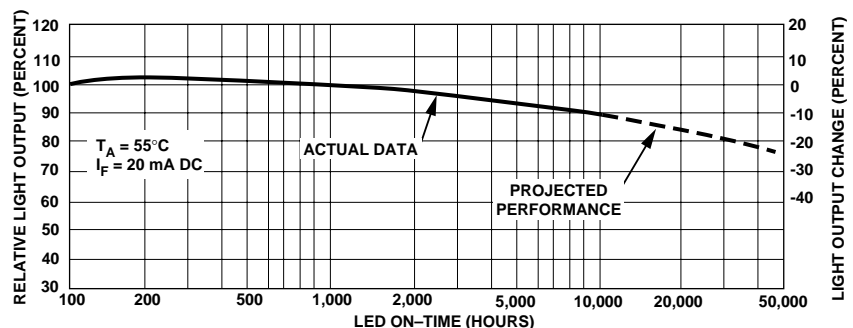

Figure 3. Statistical Average HTOL Light Output Degradation for Precision Optical Performance AllInGaP LED Lamps.

are not recommended. Operation of AlInGaP LED lamps below 10 mA usually does not produce sufficient light output for traffic management applications and is not recommended.

### **LED Light Output Degradation as Perceived by the Human Eye**

As a threshold, the human eye can just perceive a 1.5 to 1 difference between two LED light sources of the same color and configuration. This is analogous to the 1.4 to 1 threshold perception difference for the human eye viewing the standard gray scale. Therefore, an LED lamp device would have to degrade by at least 50% of its initial light output value before a motorist would perceive it as being dim. As shown in Figure 3, the predicted long term degradation for Precision Optical Performance AlInGaP LED lamps at 50,000 operational on-time hours is considerably less than a 50% reduction in light output.

### **LED Color Does Not Change Over Time**

The color of the emitted light from an LED lamp device does not change over time. Although the amount of emitted light does change over time, the color of the emitted light remains constant.

The color of the emitted light from an LED device does exhibit a small change with operating temperature, on the order of a 0.1 nm increase in wavelength for each 1°C increase in operating temperature. In the red color region, this change is not perceptible to the human eye. In the amber (yellowish-orange) color region, the human eye can detect a 3 nm difference in color. This means that two adjacent amber LED lamp

devices would have to be operating with a temperature difference of 30°C (54°F) before a color difference would be perceived by a motorist. This large a temperature difference between adjacent LED lamp devices is not likely to occur in a well designed traffic signal or VMS.

### **Operational On-Time Hours vs. Elapsed Time Calendar Hours**

Operational on-time hours are defined as the time an LED lamp device is actually on (illuminated) by action of a forward biased drive current. The time an LED is not on (not illuminated) is not part of the operational on-time hours. Elapsed time calendar hours are defined as the calendar time an LED lamp device is utilized in a traffic signal or VMS installation. Operational on-time is determined by an on-time duty factor. For example, a red traffic signal light is typically on 55% of the calendar time, thus the on-time duty factor = 0.55. For a yellow traffic signal light, the on-time duty factor is 0.05 (typically on 5% of the calendar time), and for a green traffic signal light the on-time duty factor is 0.40 (typically on 40% of the calendar time). Thus, a red LED traffic signal installation with 50,000 hours

of elapsed time calendar hours, would accumulate 27,500 operational on-time (illumination) hours. See equations in Table 1.

The AlInGaP amber LEDs that make up a VMS pixel matrix are strobed to permit displaying a character set and symbols. Typically, the average on-time duty factor is ~20% for individual LED pixels for 100% illumination for daytime conditions. During nighttime operation, the 100% illumination may be dimmed down to 12 1/2%. The actual nighttime illumination on-time duty factor is now ~2.4%. The combined weighted average on-time duty factor continuous daytime and nighttime is ~11.2%, assuming 12 hours for both daytime and nighttime.

### **MTBF for LED Devices vs. Incandescent Lamps**

The definition of MTBF is different for incandescent lamps and LED devices.

*MTBF for Incandescents:* MTBF is the statistical average time to burn-out (catastrophic failure) for a given type of incandescent lamp. To obtain this value, a selected quantity of incandescent lamps are placed on test at rated voltage in an open air

**Table 1. Operational On-Time Hour Equations**

(Elapsed Time Calendar Hours) • (On-Time Duty Factor) =	Operational On-Time Hours
(50,000 Elapsed Time Calendar Hours) • (0.55 On-Time Duty Factor) =	27,500 Operational (Illumination) On-Time Hours

room temperature environment. The time point when one half of the incandescent lamps on test have failed due to burn-out is taken as the mean time before (mean time to) failure.

*MTBF for LED Devices:* MTBF is the calculated (estimated) time between *possible* catastrophic failures of a given type of LED device. MTBF does not predict LED devices will actually fail. The failure rate, defined as  $1/\text{MTBF}$ , cannot be taken to mean the LEDs will in fact fail at that rate. LED devices typically do not fail according the  $1/\text{MTBF}$  rate, but actually last considerably longer than the MTBF value indicates.

To obtain the MTBF value, a selected quantity of LED devices are put on high temperature operating life, HTOL, test in an ambient temperature of 55°C, driven at the maximum rated dc drive current. The LED chip operating temperature is near the maximum rated LED junction temperature. The devices under test are soldered onto printed circuit test boards to simulate real life conditions. Tests are performed in accordance with the latest revision of MIL-STD-883. After a selected number of on-time hours, usually in excess of 1000 hours, none of the LED devices have failed. One failure is then assumed to determine the MTBF value for operation in the 55°C ambient. Then MTBF values for other operating temperatures are calculated using the Arrhenius Model with an activation energy of 0.43 eV, see MIL-HDBK-217.

### **Mean Time Between (Possible) Catastrophic Failures for T-1<sup>3/4</sup> LED Lamp Devices, MTBF**

The T-1<sup>3/4</sup>, untinted, non-diffused, plastic lamp is the device package of choice in LED traffic signal and LED VMS designs. The data presented here applies to this T-1<sup>3/4</sup> LED device package.

The criterion for failure in determining MTBF is catastrophic open circuit failure, the LED device no longer illuminates with forward current. MTBF for plastic LED lamp devices is independent of LED technology and is dependent on package type. MTBF is a first order function of the LED chip temperature inside the device package, measured at the semiconductor p-n junction. MTBF decreases by an approximate factor of 2.4 for each 20°C increase in LED chip temperature.

### **Predicted Possible LED Catastrophic Failure Rate:**

The predicted possible LED failure rate,  $\lambda$  in percent per 1000 hours of operation, is derived from the reciprocal of MTBF. See equation, Table 2.

As shown in Figure 4, there may possibly be a short period of time where LED failures might occur due to manufacturing related problems. Once past that period, the possible failure rate, as de-

rived from the MTBF value, will be constant over the expected operating life of an LED signal or LED VMS.

MTBF and failure rate values for plastic T-1<sup>3/4</sup> LED lamps, collected over a period of years, are given for ambient temperatures from 5°C (41°F) to 85°C (185°F) in Table 3. The required MTBF for LEDs installed in traffic signals and VMS signs is a minimum of 100,000 (11.4 years) of operation without the catastrophic failure of an LED lamp device. The data listed in Table 2 predicts MTBF values far greater than this minimum value.

**Reliability Calculation.** Predicted failure rate per 1000 hours of operation, calculated from MTBF, is used to determine the reliability factor, R(%), of a Precision Optical Performance LED lamp in a changeable message sign or traffic signal.

$$R(\%) = [e^{-\lambda t}] \cdot 100$$

Where:

R = reliability factor, percent probability of survival over a given period of time at specified operating conditions.

t = given amount of LED on-time in hours.

$\lambda$  = LED device predicted failure rate / 1000 hours =  $1000 / \text{MTBF}$ .

e = 2.7183.

**Table 2. Equation Predicting Possible LED Catastrophic Failure Rate.**

$$\lambda \text{ (\% Possible Catastrophic Failure per 1000 hours)} = 100 \cdot (1 / \text{MTBF}) \cdot 1000 \text{ hours}$$

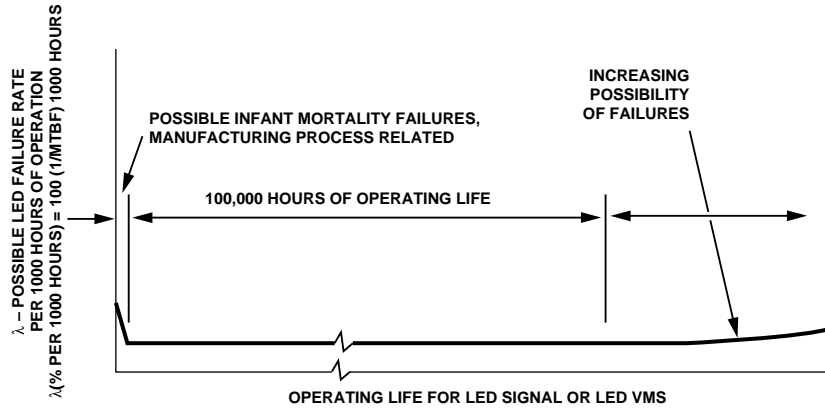

Figure 4. Typical Failure Rate Curve.

Table 3. MTBF and Failure Rate for Precision Optical Performance AllInGaP LED T-13/4 Plastic Lamps.

Ambient Operating Temperature, °C (°F)	LED Chip Temperature, °C (°F)	MTBF (Hours)	Device Failure Rate, λ (%/1K Hours)
85 (185)	103 (217)	848,000	0.118%
75 (167)	93 (199)	1,220,000	0.082%
65 (149)	83 (181)	1,791,000	0.056%
55 (131)	73 (163)	2,688,000	0.037%
45 (113)	63 (145)	4,133,000	0.024%
35 (95)	53 (127)	6,525,000	0.015%
25 (77)	43 (109)	10,701,000	0.009%
15 (59)	33 (91)	17,978,000	0.006%
5 (41)	23 (73)	30,922,000	0.003%

Assume a Precision Optical Performance AllInGaP 626 nm red LED traffic signal, which is on (illuminated) 55% of the time, is operating in a daytime ambient of 45°C (113°F) and a nighttime ambient of 5°C (41°F). Over an elapsed time period of 100,000 hours, the red LED signal is assumed to be on for 27,500 hours during daytime hours and 27,500 hours during nighttime hours for a total on-time of 55,000 hours. Thus, the reliability factor for the Precision Optical Performance AllInGaP LED lamps operating in this signal over the elapsed time period of 100,000 hours without the need for replacement is 99.26%.

From Table 1 for MTBF:  
At 45°C (113°F), the predicted possible failure rate = 0.00024 / 1000 hrs

At 5°C (41°F), the predicted possible failure rate = 0.000003 / 1000 hrs

Table 4 shows the results of using these predicted failure rate values.

Table 4.

$$R(\%) = [e^{-(\lambda_1 t_1 + \lambda_2 t_2)}] \cdot 100$$

$$R = [2.7183^{-(0.00024/1000 \text{ hrs}) \cdot (27,500 \text{ hrs}) + (0.000003/1000 \text{ hrs}) \cdot (27,500 \text{ hrs})}] \cdot 100$$

$$= [2.7183^{-(0.0066 + 0.00083)}] \cdot 100$$

$$= [2.7183^{-(0.00743)}] \cdot 100$$

$$= [0.9926] \cdot 100 = 99.26\%$$

### **What Happens to a Precision Optical Performance LED Lamp When Overheated**

As can be seen from the data in Table 3, the MTBF decreases and the corresponding possible failure rate increases with increasing temperature. However, this does not necessarily indicate a failure will occur as long as the LED chip temperature does not exceed the maximum allowed LED junction temperature. For Precision Optical Performance AlInGaP LED T-1<sup>3</sup>/<sub>4</sub> plastic lamps the maximum LED junction temperature is 130°C (266°F). If a Precision Optical Performance AlInGaP LED lamp is allowed to operate above this maximum chip junction temperature, a significant non-recoverable light loss or catastrophic failure can occur.

The normal ambient air operating temperature range for traffic signals and VMS is -40°C (-40°F) to 74°C (165°F). At the ambient temperature of 74°C (165°F), exceeding the maximum LED junction temperature limit is usually not a concern. Examination of the data in Table 3 shows that the LED chip temperature within the lamp devices will be on the order of 18°C above the ambient temperature surrounding the lamps, ignoring additional heating effects from sunlight. In summer, the exposure of a signal or VMS assembly to direct sun light could possibly increase the internal operating temperature surrounding LED lamp devices by an additional 20°C. Thus the LED chip junction temperature could reach 112°C (228°F), (112°C = 74°C + 18°C + 20°C), which is below the 130°C (266°F) maximum LED chip junction temperature limit for Precision Optical Performance AlInGaP LED lamps.

Hoods installed on traffic signals to shade the lens to increase viewability also reduce internal ambient temperature build up due to direct sunlight. VMS enclosures typically include fans to circulate air over the LED lamp devices and other circuit components inside the face of the sign to reduce temperature build up from direct sunlight.

### **Low Thermal Resistance Design and Electronic Assembly Affect LED Reliability**

The design of the packaging and electronic assemblies that comprises an LED traffic signal or LED VMS have a direct impact on the long term reliability of Precision Optical Performance LED lamp devices. Keeping the LED chip temperature rise above the ambient as low as possible by providing a low thermal resistance path to ambient air for the cathode leads of AlInGaP LED lamp devices, increases MTBF helping to ensure predicted long term reliability.

The methods, procedures, and care exercised in the electronic assembly of an LED traffic signal or LED VMS also have a direct affect on the long term reliability of the LED lamp devices. Observing industry standards for electronic assembly and paying careful attention to detail in the assembly and solder processes can help to assure the long term reliability of LED lamp devices. Poor mechanical handling, such as improper bending of device leads or over heating during soldering, can induce latent failure mechanisms in LED lamp devices that negatively affect long term reliability.

### **The Effect of Extreme Cold Temperatures**

Precision Optical Performance AlInGaP LED lamp devices are rated to operate at temperatures down to -40°C (-40°F). At these low temperatures, the MTBF value becomes very large, and the probability of failure extremely small. Therefore, operation of an LED traffic signal or VMS in cold weather should not be a concern to a transportation engineer.

### **The Effect of Long Term Exposure to High Humidity, Condensing Moisture.**

The packages of plastic LED lamp devices are cast from an optical grade epoxy. Since the emitted light from an LED chip must escape from the lamp package, filler materials cannot be added to the epoxy to enhance resistance to moisture absorption. Thus, after a period of long term exposure to a high humidity environment, especially one of condensing moisture, an optical grade epoxy will absorb water molecules at a rate which increases with increasing temperature.

Long term exposure to a condensing moisture environment in excess of 5000 hours typically can result in catastrophic failure of a Precision Optical Performance AlInGaP LED lamp. The failure occurs when the quantity of absorbed water molecules within the lamp package epoxy is of sufficient density to 1) chemically attack the aluminum top electrical contact on the LED chip, breaking the wire bond to anode electrical connection within the device, and/or 2) cause the cross-link molecular bonds within the encapsulating epoxy to break, resulting in disintegration of the lamp epoxy package.

This moisture absorption is not necessarily cumulative, but is cyclic over time with changes in relative humidity. As the relative humidity decreases to a low level, absorbed water molecules “evaporate” out from the LED lamp epoxy packages, much in the same manner as they do from an ordinary sponge as it dries out.

By simply providing protection for Precision Optical Performance LED lamps against long term exposure to high humidity, condensing moisture in the design of a traffic signal or VMS will prevent catastrophic failure due to moisture absorption from occurring. A traffic signal assembly designed as a water tight sealed unit will protect the LED lamp devices from rain, fog, and other condensation. A carefully designed VMS enclosure will protect the LED lamps from exposure to rain and fog, and may include fans to keep a constant flow of air to prevent the formation of internal condensation.

#### **The Affect of Exposure to Direct Sunlight (Ultraviolet Light)**

Hewlett-Packard Precision Optical Performance AlInGaP LED lamps have ultraviolet inhibitors in the encapsulating epoxy of the lamp packages, which reduces the absorption by the epoxy of both uv-a and uv-b by 80%. This feature significantly helps to ensure long term performance in traffic signals and VMS. However, it is recommended that the lens of a traffic signal or window face of a VMS provide an additional 80% absorption of both uv-a and uv-b to provide positive assurance that no degradation of the LED lamp epoxy packages can possibly occur with direct exposure to sunlight during the life of the unit.

#### **Typical Failure Modes for Precision Optical Performance Plastic T-1 3/4 LED Lamps**

LED lamps can experience common failure modes either during pc board assembly, or as a result of being connected to inadequately designed circuits, or installed in poorly designed housings.

#### **Typical Failure Modes Due to Poor PC Board Assembly**

**Methods:** When installed in printed pc boards with modern day assembly processing and positive quality control, Precision Optical Performance AlInGaP LED lamps will last for very long times. The two most common failure modes due to poor pc board assembly processing are 1) broken wire bonds, Figure 5a, and 2) cracked plastic domes, Figure 5b. Broken wire bonds are typically caused by over heating of the LED lamp device during soldering. These failures are typically catastrophic and usually show up at electrical test after the soldering operation. Cracked lamp package domes are usually caused by trying to bend lamps into position after soldering. The bending stresses in the lead frames are transmitted to the encapsulating epoxy, causing the epoxy to crack. The cracked dome failure mode may not be easily detectable during product assembly and may show up later as latent field failures.

Both of these failure modes can be prevented by following accepted industry pc board assembly standards and incorporating an in-process quality control system.

#### **Typical Field Failure Modes:**

The three most common field failure modes, see Figure 6, are 1) a 50% reduction in light loss, non-

recoverable, due to over heating, 2) a catastrophic failure due to excessive current, and 3) deterioration of the encapsulating epoxy due to long term moisture absorption.

When the temperature of the LED chip exceeds the maximum limit, the encapsulating epoxy immediately surrounding the LED chip may undergo a post cure, causing it to shrink away from the LED chip, as shown in Figure 6a. This forms a void between the LED chip and the epoxy. This void causes a Fresnel loss of LED emitted light on the order of 50%, non-recoverable.

A high forward current surge through an LED lamp, usually in excess of 500 mA for 10 ms, can cause an open circuit catastrophic failure, Figure 6b, breaking the anode-to-cathode electrical connection within the LED lamp. The open circuit failure can be a burned (destroyed) top contact on the LED chip and/or an open circuit bond wire, much like that of an open circuit fuse.

Long term exposure to condensing moisture is the primary reason for the encapsulating epoxy dome of a plastic LED lamp deteriorating, as illustrated in Figure 6c. Steady state exposure to condensing moisture over time will cause cloudiness and discoloration as the concentration of absorbed moisture within the lamp epoxy dome package reaches a high value. Continued exposure to the condensing moisture environment will eventually result in catastrophic failure by corroding the LED active aluminum top contact, breaking the anode-to-cathode electrical connection within the lamp, and in time will cause decomposition of the epoxy.



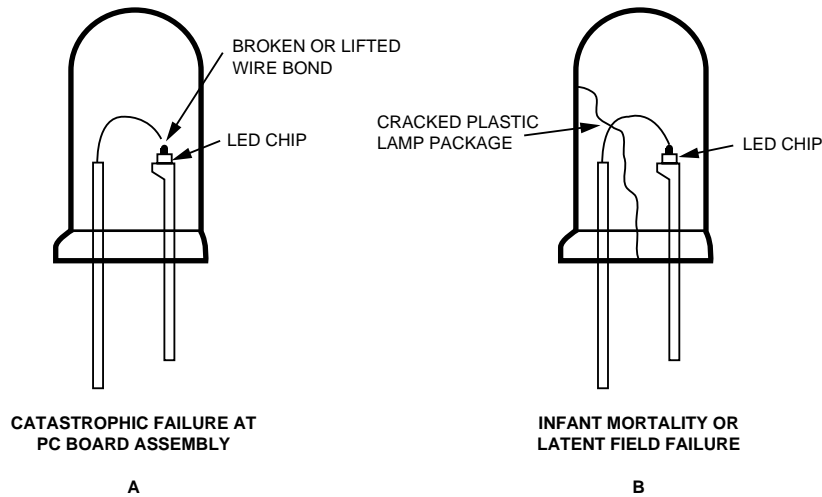

**Figure 5. Typical LED Failure Modes That Can Occur at PC Board Assembly Due to Poor Process Control.**

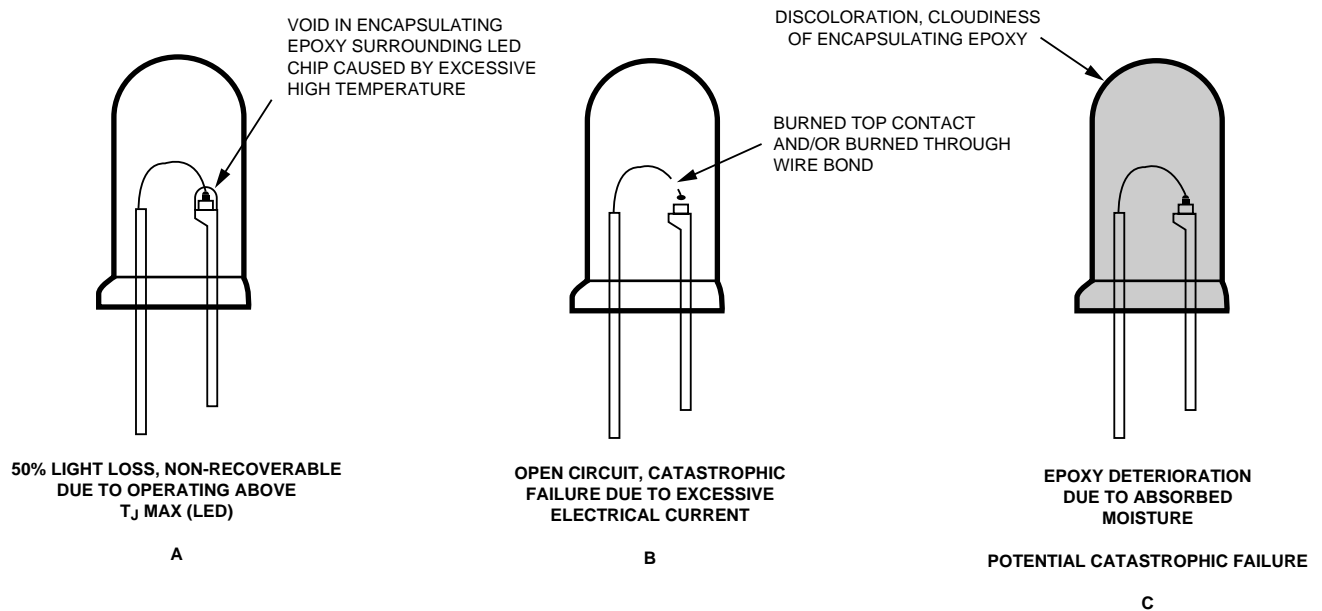

**Figure 6. Typical LED Field Failure Modes That Can Occur with Excessive Current Drive or Inadequate Packaging Design.**

All of these failure modes can be prevented by 1) designing the pc board for low thermal resistance-to-ambient air, thus reducing the LED junction temperature rise to a minimum, 2) providing adequate overvoltage surge protection, thereby reducing the

possibility of a high current transient that exceeds the maximum allowable LED drive current, and 3) designing the housing to provide sufficient protection from long term exposure to condensing moisture.



For technical assistance or the location of your nearest Hewlett-Packard sales office, distributor or representative call:

**Americas/Canada:** 1-800-235-0312 or (408) 654-8675

**Far East/Australasia:** Call your local HP sales office.

**Japan:** (81 3) 3335-8152

**Europe:** Call your local HP sales office.

Data Subject to Change

Copyright © 1997 Hewlett-Packard Co.

Obsoletes 5965-6223E

Printed in U.S.A. 5965-8097E (4/97)